

## Technical specification sheet

Product name	: <b>Universal Periapical UL/LR sensor holder size #2</b>
Sheet #	: TECH2022UL
Colour	: Orange, based on UN2338
Artical code	: 2022UL
General purpose	: Holder for Dental Intraoral X-ray sensor size #2 for Periapical images, Upper Left and Lower Right
Fits for sensor size	: All common size #2 sensors ( wired or wireless)
Material	: PBT POCAN B1501
Technics	: Injection moulding
Certificates	: CE: NL/CA01/2006-02593, FDA pending
Recycle	: yes
Accessoiries	: Hygiene sleeves, Positioning ring
Supplied as	: As package only
	Refill's: standard package as a box of 5 pc's, see product DBU2022.
	As part of introduction kit: 1 pc per kit see product DBU2062.
	Both also under several privat labels.

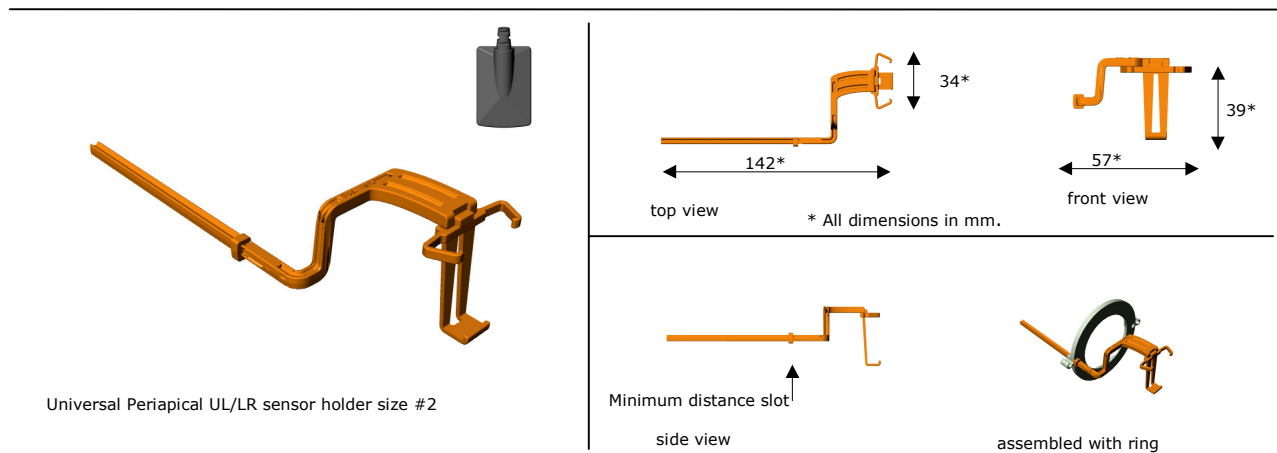

### Application

Positioning of dental X-ray sensor size #2 for periapical images. The sensor is placed in a vertical position into the holder which is positioned between upper and lower jaw which enables a posterior image of the required area. Limited to the Upper Left and the Lower Right.

### Positions to use

All positions for periapical images of the Upper Left and Lower Right jaw. Rotate the holder to change holder position in ring to select right or left side position in the mouth.

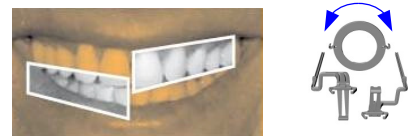

### Instructions voor placing sensor into holder

- Hold the holder between thumb and finger by the bite area,
- 1 slide the sensor into one of the clamps,
  - 2 press de sensor in the other clamp
  - 3 untill the click.
  - 4 slide the sensor downwards

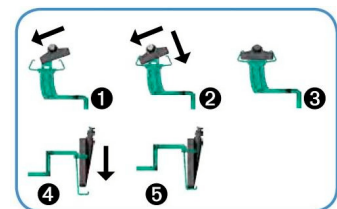

### Note's of use

The sensor must be placed into a sensor sleeve before placing into the holder. The sensor and holder must be placed into the positioning ring to optimize centering of the sensor to the cone. The sensor cable (if present) can be fixed to the holder by the cable clip on the positioning ring. Bring the cable out on the other side of the mouth to prevent damage by biting. Centralize the cone to the sensor by checking position to the ring and the holderrod. Do not click or clamp the cone to the ring.

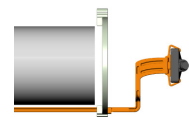

### General hygiens notes

Use a hygiene sleeve before placing into the holder on every patient. The BiteWing sensor holder size #1 must be sterilized before first use and before use on every patient. Use the Autoclave or thermodesinfector by 134° C / 273° F

### General terms

DenBite® X-ray sensor holders are manufactured by DuPhaMed B.V. Patent pending.  
 © 2005 DuPhamed B.V. - Alphen aan den Rijn, The Netherlands.  
 All rights reserved, Other Brands and products are Trademarks of their respective holders  
 All technical specification's are subject to be changed without prior notification.